



Mounting Structure

USER MANUAL



1. Introduction



Figure 1 – Four-directional mounting structure

The Mounting Structure is a metal framework made of custom-made brackets and materials designed for the installation of SEVEN meteorological sensors. It is manufactured from AISI 304 stainless steel.

The structure supports the mounting of following sensors: Irradiance Sensor, Ambient Temperature Sensor, Wind Speed Sensor, Wind Direction Sensor, Relative Humidity Sensor, and Pyranometer. Each sensor uses a dedicated custom-made bracket, which is bolted to the appropriate position on the mounting structure profiles. All mechanical fasteners including bolts, nuts, and washers are made of stainless steel.

Irradiance Sensors can be configured in 1, 2, 3, or 4 directions depending on customer requirements. These configurations are achieved using additional profile extensions and sensor mounting brackets.

SEVEN products use reliable and high-quality components to provide accurate meteorological information in environmental and industrial applications.



Note: SEVEN reserves the right to make changes to this document without prior notice.

2. Contact Information

Please feel free to contact us if you face any difficulties during installation.

Address	Pinarçay OSB Mahallesi 11. Cadde, No: 35, Corum Organize Sanayi Bolgesi 19200 Merkez / Corum / Türkiye
Phone	+90 553 892 26 70 / +90 501 102 88 70
E-mail	teknik@sevensensor.com
Website	www.sevensensor.com

3S-MS

Mounting Structure User Manual

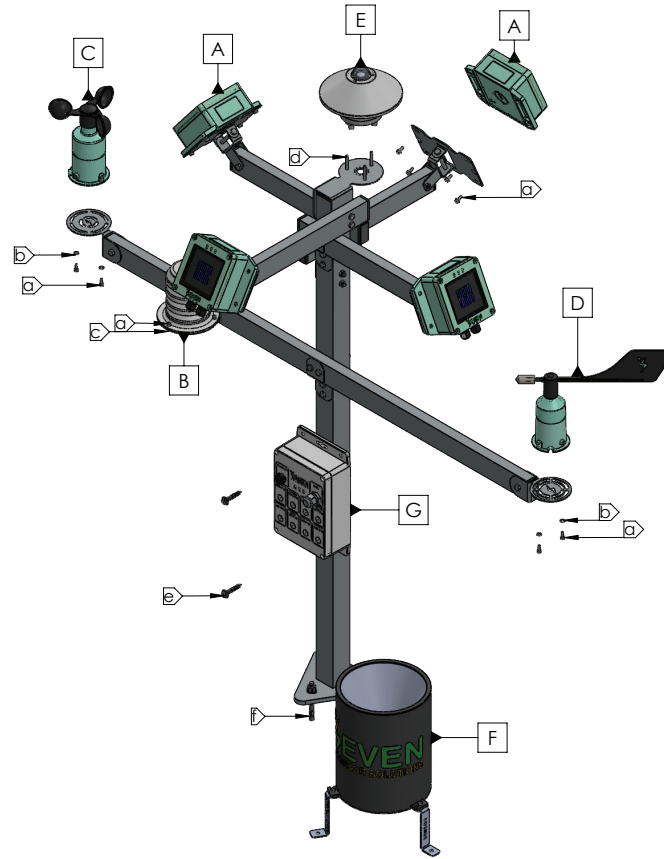







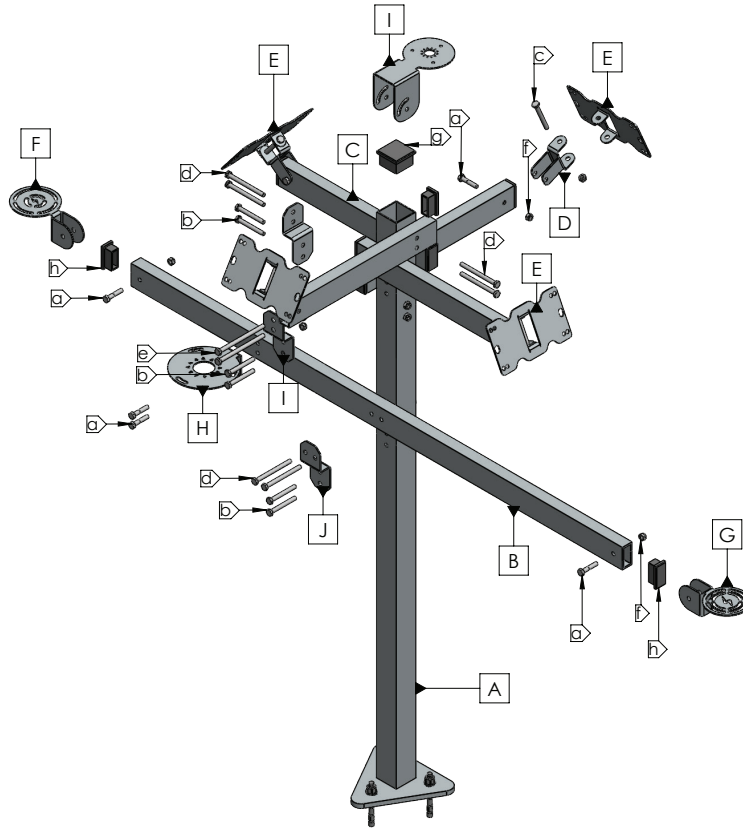





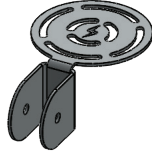

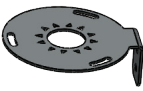
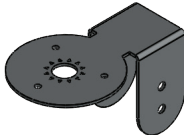
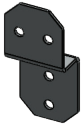
A Qty:4	B Qty:1	C Qty:1	D Qty:1	
Irradiance Sensor	Ambient Temperature Sensor	Wind Speed Sensor	Wind Direction Sensor	
E Qty:1	F Qty:1	G Qty:1	a Qty:23	
Pyranometer	Precipitation Sensor	Electronic Box	Stainless Steel M4x10 mm Socket Head Cap Screw	
b Qty:29	c Qty:3	d Qty:3	e Qty:2	f Qty:3
Stainless Steel M4 Washer	Stainless Steel M4 Nut	Stainless Steel M4x30 mm Socket Head Cap Screw	Stainless Steel M6.3x38 mm Self-Tapping Screw	Stainless Steel M8x75 mm Anchor Bolt

3S-MS

Mounting Structure User Manual



					
A Qty:1	B Qty:1	C Qty:4	D Qty:4	E Qty:4	F Qty:1
Mounting Post 40x40x1000 mm Profile	20x40x1000mm Profile	20x40x300 mm Profile	Irradiance Sensor Support Bracket	Irradiance Sensor Mounting Bracket	Wind Speed Sensor Mounting Bracket
					
G Qty:1	H Qty:1	I Qty:1	J Qty:3	a Qty:8	b Qty:6
Wind Direction Sensor Mounting Bracket	Ambient Temperature Sensor Mounting Bracket	Pyranometer Mounting Bracket	Support Bracket	Stainless Steel M6x30 mm Hex Head Bolt	Stainless Steel M6x50 mm Hex Head Bolt
					
c Qty:4	d Qty:6	e Qty:2	f Qty:26	g Qty:1	h Qty:10
Stainless Steel M6x60 mm Hex Head Bolt	Stainless Steel M6x70 mm Hex Head Bolt	Stainless Steel M6x90 mm Hex Head Bolt	Stainless Steel M6 Nylon Lock Nut	40x40 mm Profile End Cap	20x40 mm Profile End Cap



Note: Quantities may vary depending on the sensors being installed.



Note: Follow the installation steps in order.

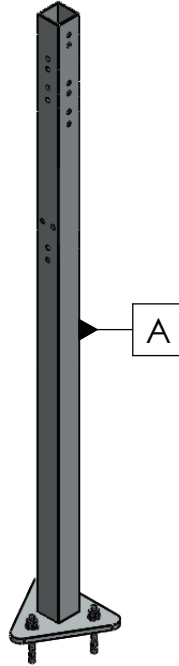

1. Check and verify the quantities of all items in the package. Mounting brackets may have slight deformations and can be straightened by hand before installation. The 1-meter mounting post is secured to the ground using three M8×75 mm anchor bolts. Use a spirit level to confirm the surface is level. If the surface is concrete, installation should be carried out using customer-supplied anchor bolts.

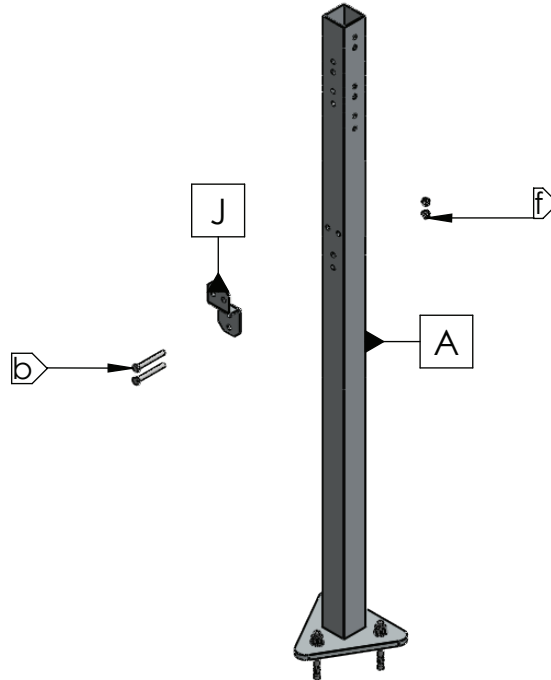

2. Attach one support bracket [J] to the post using two M6×50 mm hex head bolts [b] and two M6 nuts [f]. The maximum torque must not exceed 6,3 Nm. Exceeding this value may cause deformation or perforation of the profile.

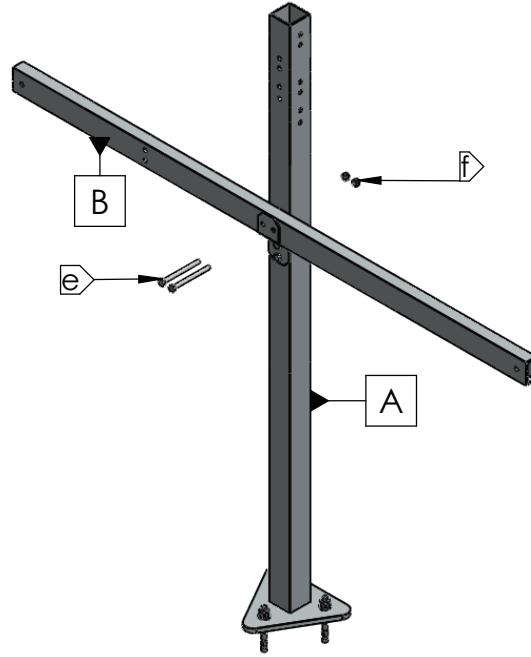

3. Fit the 20×40×1000 mm profile [B] into the gap between the support bracket and the mounting post. Align the holes of the profile and bracket before tightening. Secure to the mounting post using two M6×70 mm hex head bolts [e] and two M6 nuts [f]. The maximum torque must not exceed 8,2 Nm. Exceeding this value may cause deformation or perforation of the profile.

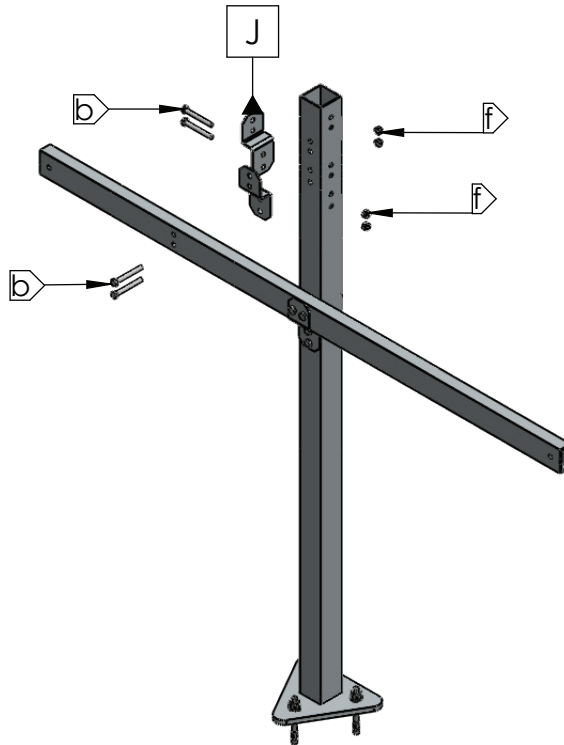

4. Attach two support brackets [J] at the positions shown in the figure, each secured with two M6×50 mm hex head bolts [b] and two M6 nuts [f]. The 20×40×300 mm profiles [C] will be mounted onto these brackets. The maximum torque must not exceed 8,2 Nm. Exceeding this value may cause deformation or perforation of the profile.

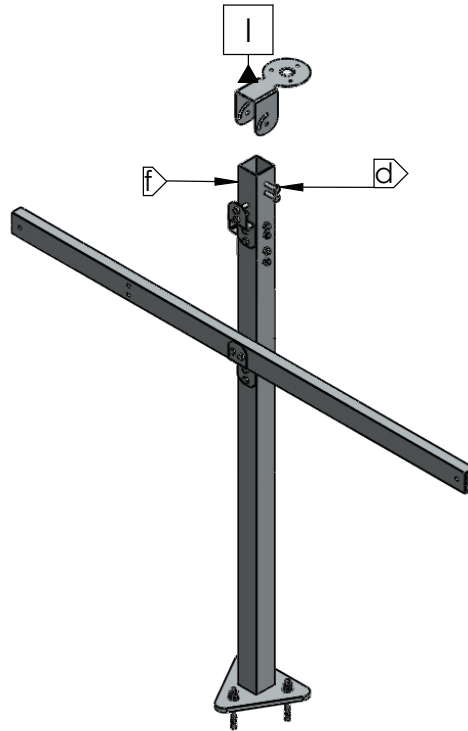

5. Mount the pyranometer bracket [I] to the top of the mounting post as shown. The angle can be adjusted between 0 and 90 degrees. Fasten using two M6×70 mm hex head bolts [d] and two M6 nuts [f]. The bracket may have slight deformations, straighten by hand before mounting and verify the tilt angle using a spirit level. The maximum torque must not exceed 12,1 Nm. Exceeding this value may cause deformation or perforation of the profile.

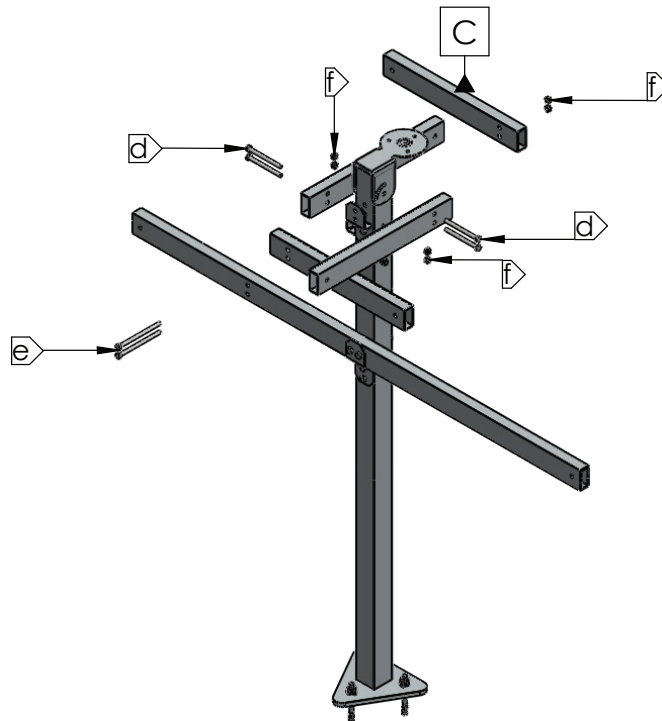

6. Align the four 20×40×300 mm profiles [C] with the holes on the mounting post. The profiles must face in opposite directions. Secure to the mounting post using two M6×90 mm hex head bolts [e], four M6×70 mm hex head bolts [d], and six M6 nuts [f]. The maximum torque must not exceed 7,1 Nm. Exceeding this value may cause deformation or perforation of the profile.

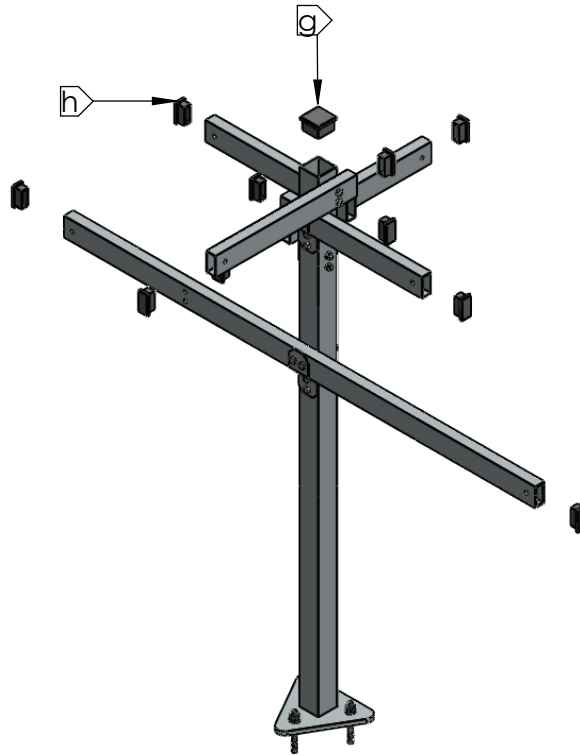

7. Once the profile assembly is complete, fit the plastic profile plug onto the open ends of the profiles. Ten 20×40 mm profile end caps [h] and one 40×40 mm profile end cap [g] are required. Ensure the end caps are fully seated and flush with the profile ends as shown in the figure.

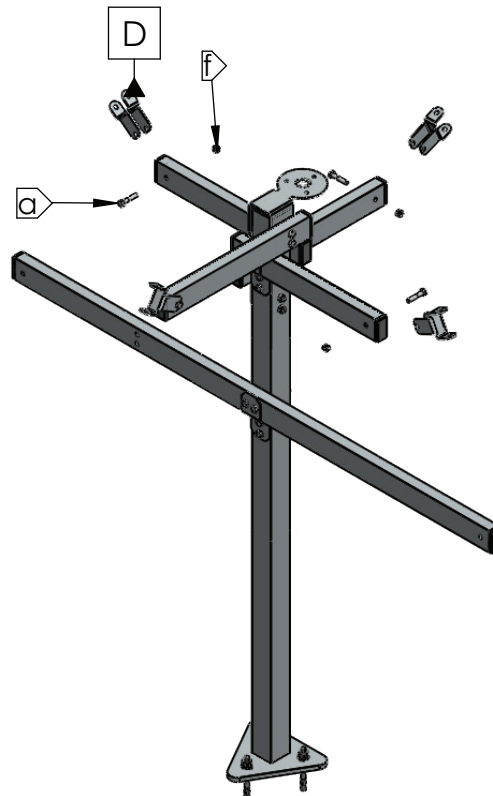

8. Mount the four irradiance sensor support brackets [D] onto the profiles as shown in the figure, each secured with one M6×30 mm hex head bolt [a] and one M6 nut [f]. Set the irradiance sensor angle at this stage. The maximum torque must not exceed 8,8 Nm. Exceeding this value may cause deformation or perforation of the profile.

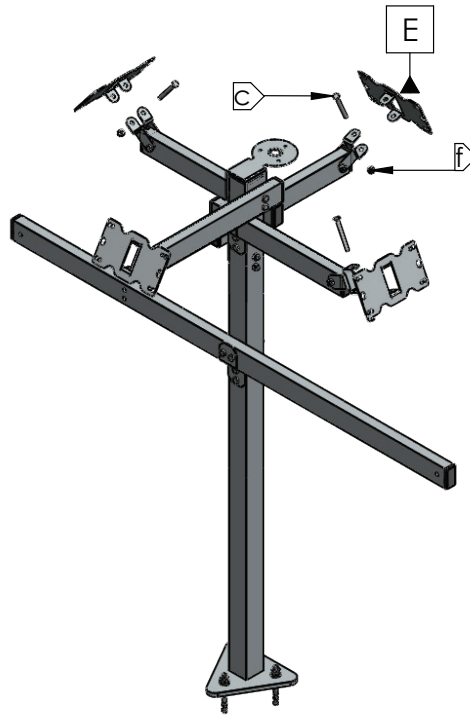

9. Attach the irradiance sensor mounting bracket [E] to the irradiance sensor support bracket [D] using one M6×60 mm hex head bolt [c] and one M6 nut [f]. Adjust parts [E] to the desired irradiance sensor position and tighten securely.

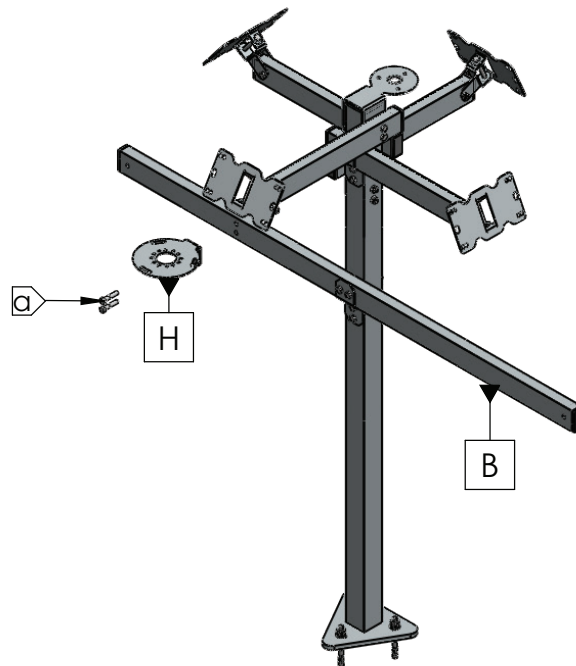

10. Mount the ambient temperature sensor bracket [H] onto the 20×40×1000 mm profile [B] as shown. Fasten using two M6×30 mm hex head bolts [a] and two M6 nuts [f]. The bracket may have slight deformations, straighten by hand before mounting and verify the tilt angle using a spirit level. The maximum torque must not exceed 8,8 Nm. Exceeding this value may cause deformation or perforation of the profile.

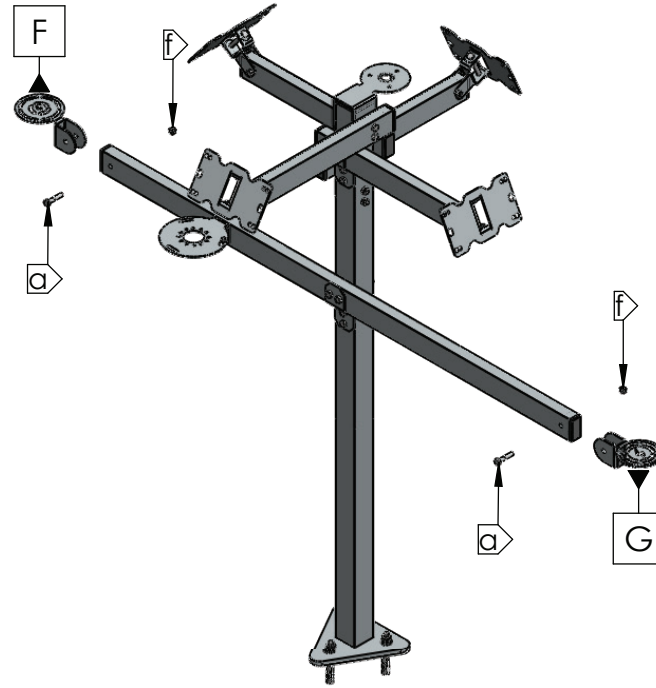

11. Mount the wind speed sensor bracket [F] and the wind direction sensor bracket [G] onto the 20×40×1000 mm profile [B] as shown. Fasten each bracket using one M6×30 mm hex head bolt [a] and one M6 nut [f]. The brackets may have slight deformations, straighten by hand before mounting and verify the tilt angle using a spirit level. The maximum torque must not exceed 8,8 Nm. Exceeding this value may cause deformation or perforation of the profile.

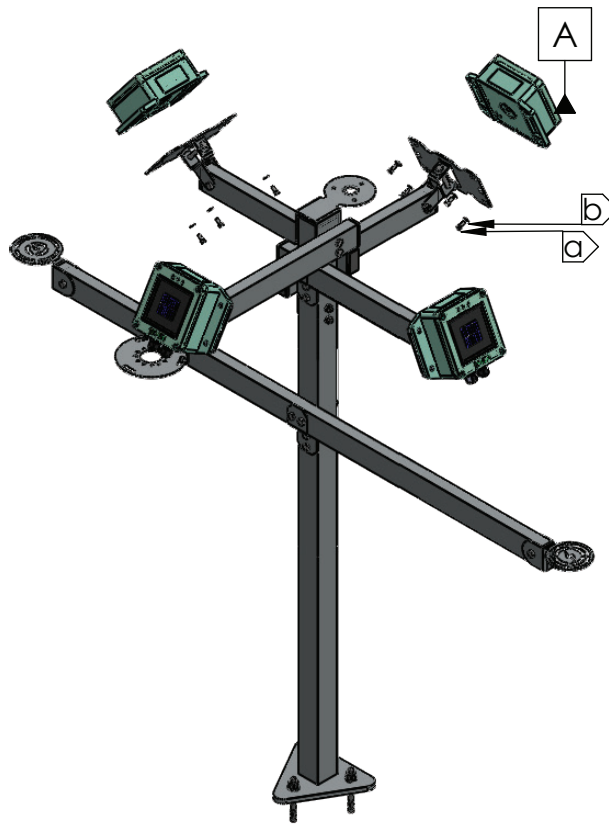

12. Install the four irradiance sensors [A] onto their brackets as shown. Secure each sensor using four M4×10 mm allen head bolts [a] and four M4 washers [b]. Use the angle indicators to verify the orientation of each irradiance sensor.

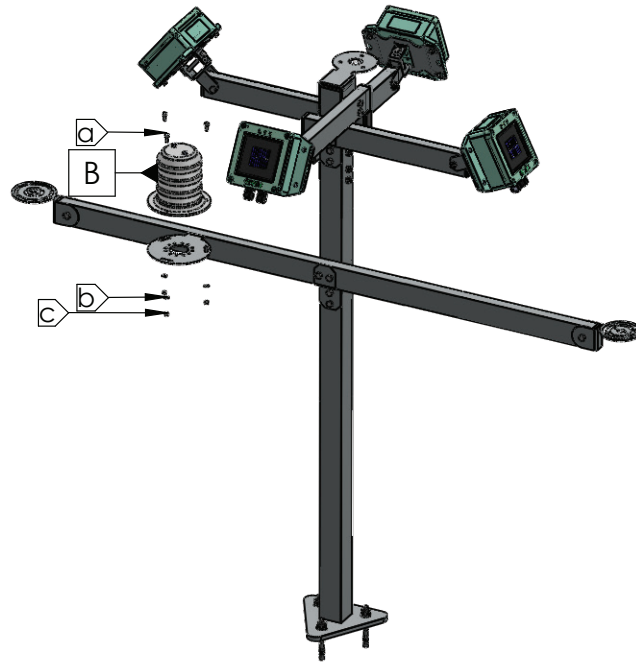

13. Attach the ambient temperature sensor [B] to its bracket using three M4×10 mm allen head bolts [a], three M4 washers [b], and three M4 nuts [c].

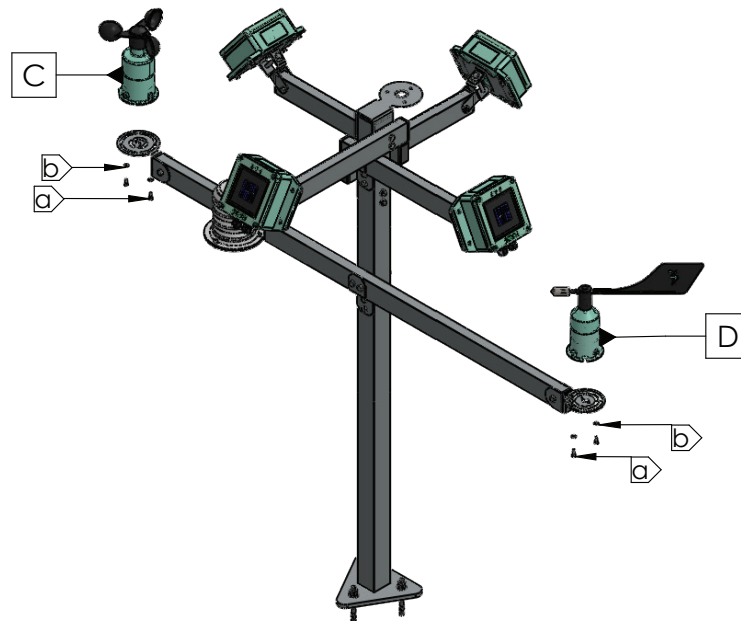

14. Attach the wind speed sensor [C] to its bracket using two M4×10 mm allen head bolts [a] and two M4 washers [b]. Attach the wind direction sensor [D] to its bracket using two M4×10 mm allen head bolt [a] and two M4 washers [b].



15. Attach the pyranometer [E] to its bracket using three M4×30 mm allen head bolts [d].

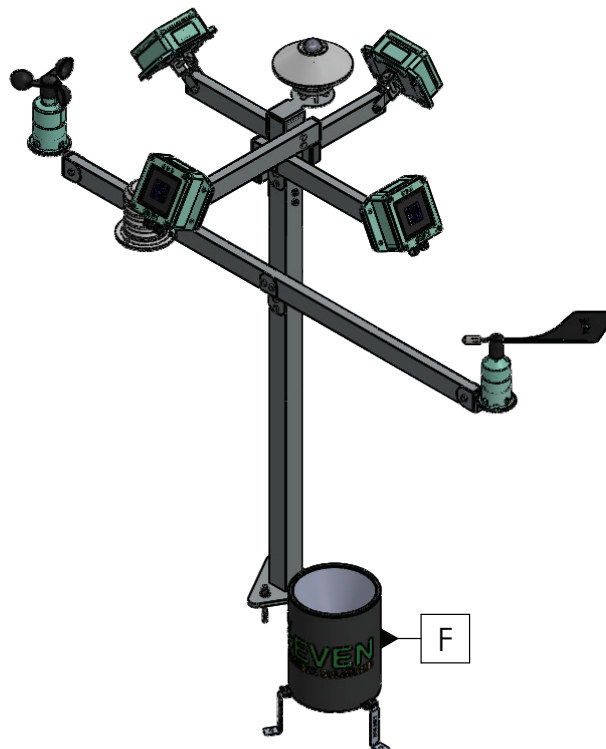

16. Place the precipitation sensor [F] on a flat surface close to the mounting structure. Level it using the built-in spirit level and secure it to the ground using the provided bolts.

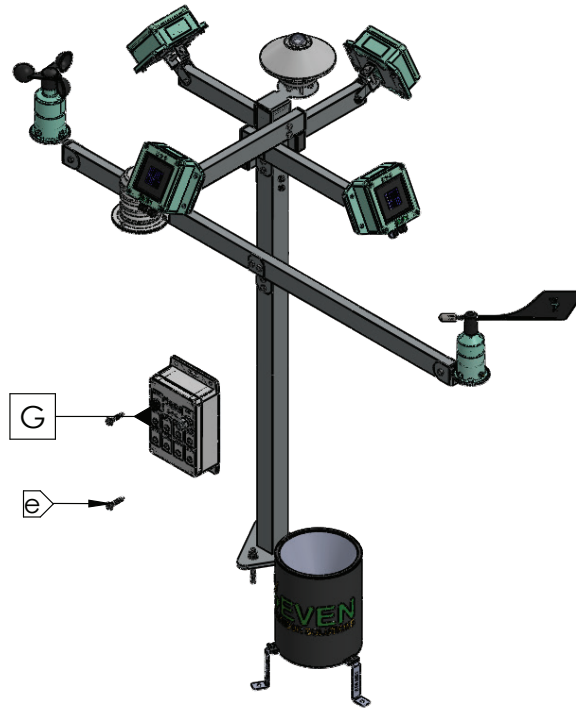

17. Secure one electrical enclosure [G] to the mounting post using two M6.3×38 mm trapezoid screws [e]. The enclosure should be mounted at a height of between 300 mm and 500 mm from the ground. When drilling through the profile with the self-tapping screw, ensure the screw is centered on the profile.